

Globe valve actuator with fail-safe for 2-way and 3-way globe valves

- Actuating force 1000 N
- Nominal voltage AC 230 V
- Control 3-point
- Stroke 20 mm

Technical data

Electrical data	Nominal voltage	AC 230 V
	Nominal voltage frequency	50/60 Hz
	Nominal voltage range	AC 85...265 V
	Power consumption in operation	2 W
	Power consumption in rest position	1 W
	Power consumption for wire sizing	4.5 VA
	Connection supply / control	Cable 1 m, 4 x 0.75 mm ²
	Parallel operation	Yes (note the performance data)
Functional data	Actuating force motor	1000 N
	Setting fail-safe position	Spindle retracted / extended, adjustable (POP rotary knob)
	Manual override	with push-button
	Stroke	20 mm
	Running time motor	150 s / 20 mm
	Running time fail-safe	35 s / 20 mm
	Sound power level, motor	56 dB(A)
	Sound power level, fail-safe	60 dB(A)
	Position indication	Mechanically, 5...20 mm stroke
	Safety	Protection class IEC/EN
Protection class UL		UL Class 2 Supply
Degree of protection IEC/EN		IP54
Degree of protection NEMA/UL		NEMA 2
Enclosure		UL Enclosure Type 2
EMC		CE according to 2014/30/EU
Low voltage directive		CE according to 2014/35/EU
Certification IEC/EN		IEC/EN 60730-1 and IEC/EN 60730-2-14
Certification UL		cULus according to UL60730-1A, UL60730-2-14 and CAN/CSA E60730-1:02
Certification UL note		The UL marking on the actuator depends on the production site, the device is UL-compliant in any case
Mode of operation		Type 1.AA
Rated impulse voltage supply / control		4 kV
Control pollution degree		3
Ambient temperature		0...50 °C
Storage temperature		-40...80 °C
Ambient humidity		Max. 95% r.H., non-condensing
Servicing		maintenance-free
Weight	Weight	2.1 kg
Terms	Abbreviations	POP = Power off position / fail-safe position CPO = Controlled power off / controlled fail-safe PF = Power fail delay time / bridging time

Safety notes



- This device has been designed for use in stationary heating, ventilation and air-conditioning systems and must not be used outside the specified field of application, especially in aircraft or in any other airborne means of transport.
- Outdoor application: only possible in case that no (sea) water, snow, ice, insolation or aggressive gases interfere directly with the actuator and that is ensured that the ambient conditions remain at any time within the thresholds according to the data sheet.
- Only authorised specialists may carry out installation. All applicable legal or institutional installation regulations must be complied during installation.
- The switch for changing the direction of motion and so the closing point may be adjusted only by authorised specialists. The direction of motion is critical, particularly in connection with frost protection circuits.
- The device may only be opened at the manufacturer's site. It does not contain any parts that can be replaced or repaired by the user.
- Cables must not be removed from the device.
- The device contains electrical and electronic components and must not be disposed of as household refuse. All locally valid regulations and requirements must be observed.

Product features

- Mode of operation** The actuator moves the valve to the desired operating position at the same time as the integrated capacitors are loaded. Interrupting the supply voltage causes the valve to be moved to the selected fail-safe position by means of stored electrical energy.
- Pre-charging time (start up)** The capacitor actuators require a pre-charging time. This time is used for charging the capacitors up to a usable voltage level. This ensures that, in the event of a power failure, the actuator can move at any time from its current position into the preset fail-safe position. The duration of the pre-charging time depends mainly on how long the power was interrupted.

Typical pre-charging time

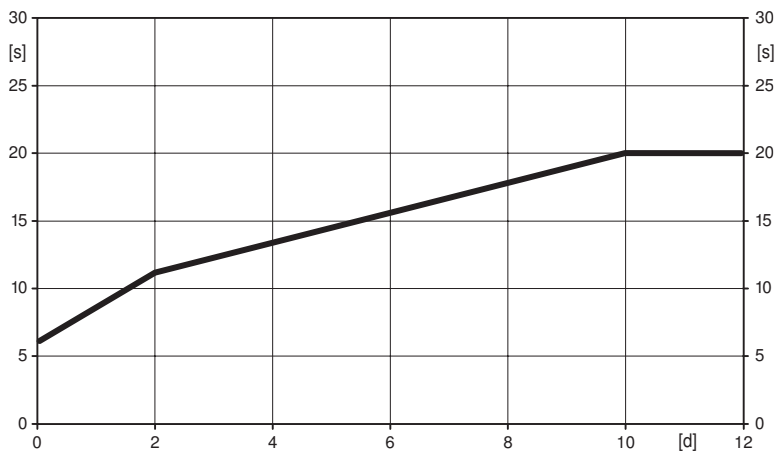

[d] = Electricity interruption in days
[s] = Pre-charging time in seconds

Delivery condition (capacitors)

The actuator is completely discharged after delivery from the factory, which is why the actuator requires approximately 20 s pre-charging time before initial commissioning in order to bring the capacitors up to the required voltage level.

Product features

Installation on third-party valves	The retrofit actuators for installation on a wide range of valves from various manufacturers are comprised of an actuator, bracket, universal valve neck adapter and universal valve stem adapter. Adapt the valve neck and valve stem to begin with, then attach the retrofit bracket to the valve neck adapter. Now fit the retrofit actuator into the bracket and connect it to the valve. Whilst taking the position of the valve closing point into account, secure the actuator to the bracket and then conduct the commissioning process. The valve neck adapter/actuator can be rotated through 360° on the valve neck, provided it is permitted by the size of the installed valve.
Installation on Belimo valves	Use standard actuators from Belimo for mounting on Belimo globe valves. The installation of retrofit actuators on Belimo globe valves is technically possible.
Manual override	Manual control with push-button possible - temporary. The gear is disengaged and the actuator decoupled for as long as the button is pressed. The stroke can be adjusted by using a hexagon socket screw key (4 mm), which is inserted into the top of the actuator. The stroke shaft extends when the key is rotated clockwise.
High functional reliability	The actuator is overload protected, requires no limit switches and automatically stops when the end stop is reached.
Position indication	The stroke is indicated mechanically on the bracket with tabs. The stroke range adjusts itself automatically during operation.
Home position	Factory setting: Actuator spindle is retracted.
Setting direction of stroke	When actuated, the stroke direction switch changes the running direction in normal operation. The stroke direction switch has no influence on the fail-safe position which has been set.
Setting fail-safe position (POP)	The rotary knob fail-safe position can be used to adjust the desired fail-safe position. The setting range always refers to the maximum height of stroke of the actuator. In the event of a power failure, the actuator will move into the selected fail-safe position, taking into account the bridging time (PF) of 2 s which was set ex-works.

Accessories

	Description	Type
Electrical accessories	Auxiliary switch 2 x SPDT add-on	S2A-H

Electrical installation

	Notes	<ul style="list-style-type: none"> • Caution: Power supply voltage! • Parallel connection of other actuators possible. Observe the performance data. • Direction of stroke switch factory setting: Actuator spindle retracted (▲).
---	--------------	---

Wiring diagrams

Electrical installation

AC 230 V, 3-point

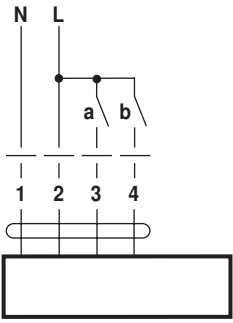

a	b		
		↓	↑
		—	—
		↑	↓
		↓	↑

Cable colours:

- 1 = black
- 2 = red
- 3 = white
- 4 = white

Operating controls and indicators

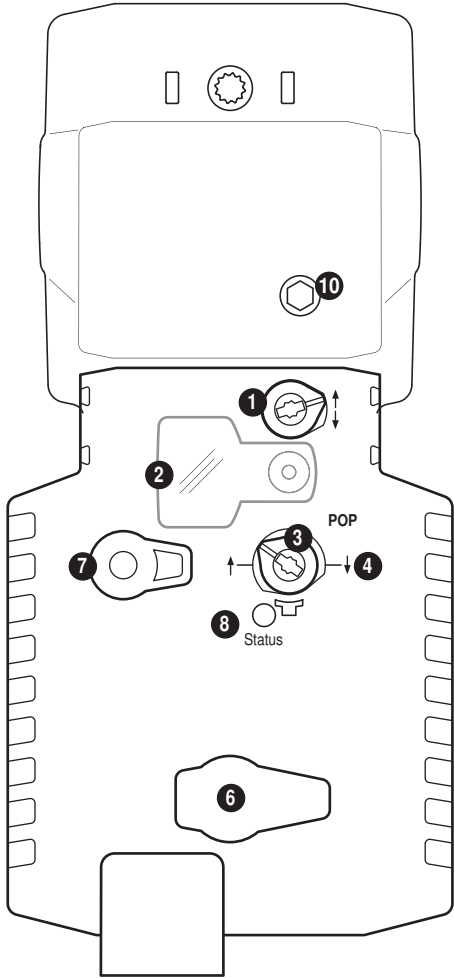

- 1 Direction of stroke switch**
Switch over: Direction of stroke changes
- 2 Cover, POP button**
- 3 POP button**
- 4 Scale for manual adjustment**
- 6 (no function)**
- 7 Disengagement button**
Press button: Gear disengages, motor stops, manual override possible
Release button: Gear engages, synchronisation starts, followed by standard mode

LED display	Meaning / function
8 green	
On	Operation OK / without fault
Flashing	POP function active
Off	– Not in operation – Pre-charging time SuperCap – Fault SuperCap

- 10 Manual override**
Clockwise: Actuator spindle extends
Counterclockwise: Actuator spindle retracts

Setting emergency setting position (POP)

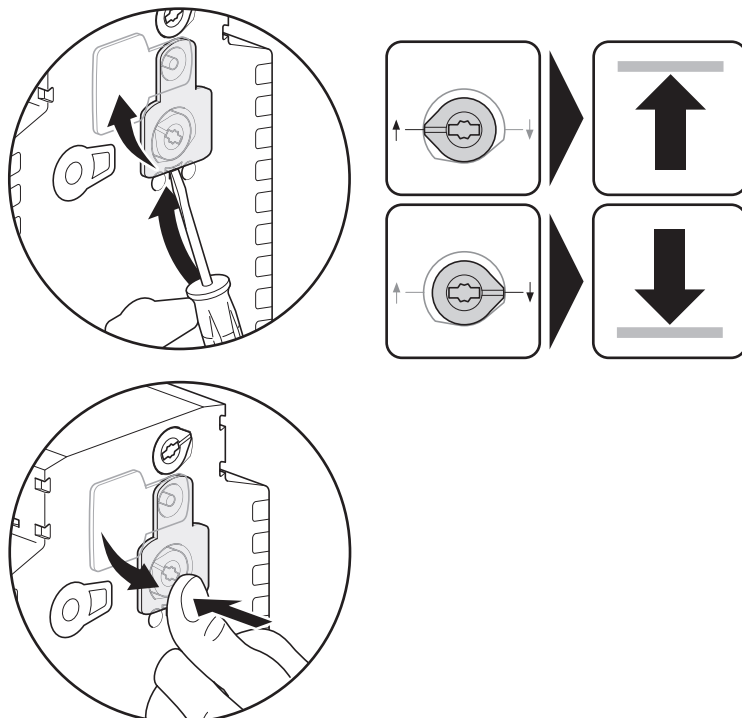

Dimensions [mm]

Dimensional drawings

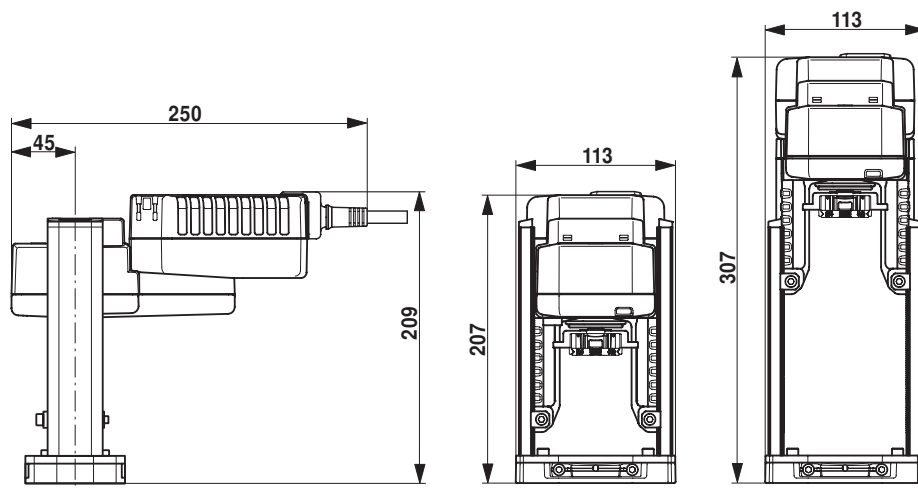

Further documentation

- Installation instructions for actuators